

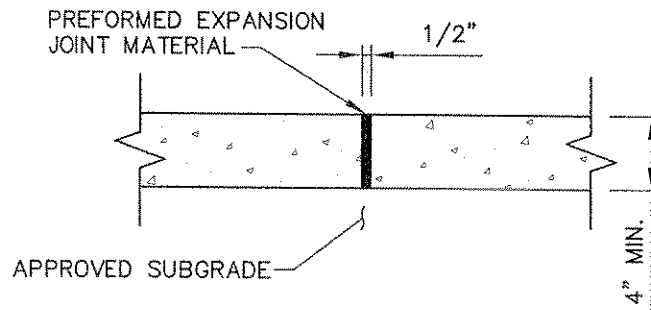

NOTES:

1. CONCRETE SHALL BE SHA MIX NO. 3.
2. CONTRACTION JOINTS AT 5'-0" INTERVALS.
3. EXPANSION JOINTS AT INTERVALS NOT GREATER THAN 20'-0".
4. ALL UNPAVED AREAS WITHIN STREET SIDELINES SHALL BE SEEDED OR SODDED PER SPECIFICATIONS.
5. SIDEWALKS AT DRIVEWAY LOCATIONS TO BE 6" THICK WITH 6" x 6" WOVEN WIRE MESH.
6. WHERE CONTINUOUS WIDTH OF TRAVEL IS LESS THAN 5'-0", PROVIDE SIDEWALK PASSING ZONES AT AN INTERVAL NOT TO EXCEED 200' CENTER TO CENTER. ENTRANCES SHALL BE ACCEPTABLE PASSING ZONES PROVIDED PAVING WIDTH OF 5'-0" IS MAINTAINED AT 48:1 (1/4" PER FT) SLOPE.



C:\dwg-files\Easton MD\DETAILS\PW-3.01.dwg Mar 30, 2007 - 3:46pm, (NORD)

APPROVAL	REVISED	TOWN OF EASTON AND EASTON UTILITIES STANDARD DETAILS  BRICK SIDEWALK
 TOWN ENGINEER	FEB 1, 06	
	MAR 26, 07	
ISSUED: JAN 1, 2000		STANDARD NO. PW-3.01