

P:\STANDARD\DETAILS\8000 City Details\Easton MD\DETAILS\PW-4.03.dwg Feb 20, 2009 - 1:54pm, (rcrs)

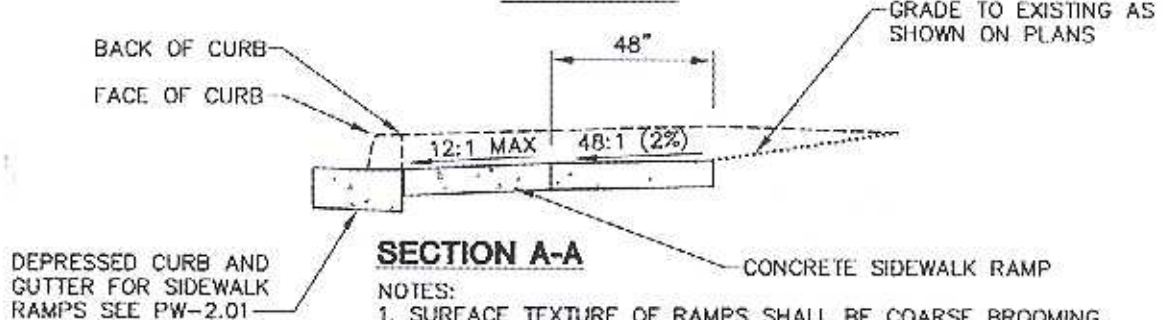
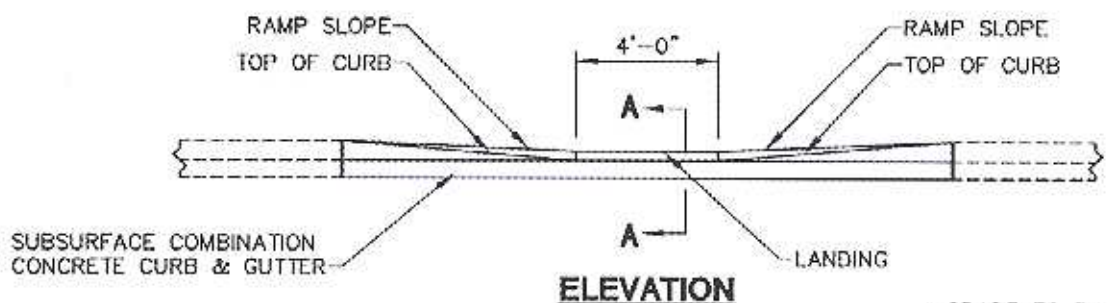
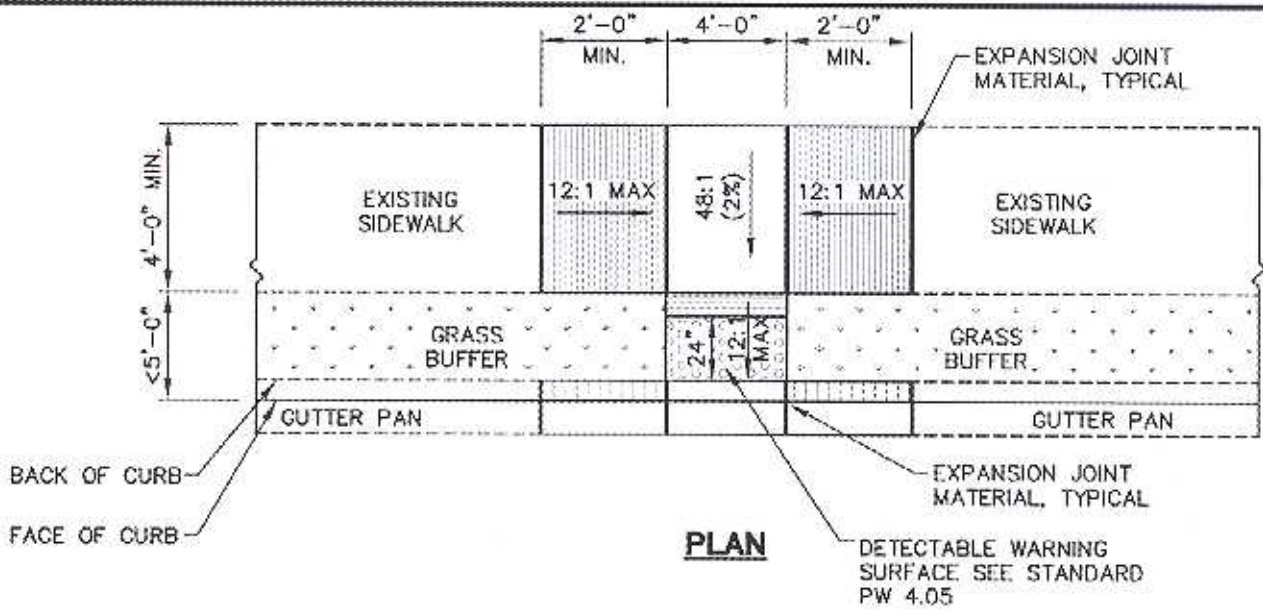

- NOTES:**
1. SURFACE TEXTURE OF RAMPS SHALL BE COARSE BROOMING OR NON-SKID TYPE SURFACE.
  2. NO TRAVERSABLE SLOPE ON THE RAMP OR SIDEWALK SHALL EXCEED 12:1 IN THE DIRECTION OF PEDESTRIAN TRAVEL, OR 48:1 (2%) PERPENDICULAR TO THE DIRECTION OF PEDESTRIAN TRAVEL.
  3. TO BE USED IN SITUATION WHERE LESS THAN 5'-0" EXISTS BETWEEN THE FACE OF CURB AND THE FRONT OF SIDEWALK.

**APPROVAL**

*M. Frandel* 2/25/09  
TOWN ENGINEER DATE

**REVISED**

FEB 25, 09

TOWN OF EASTON  
AND  
EASTON UTILITIES  
STANDARD DETAILS  
TYPE "D" SIDEWALK  
RAMP FOR RETROFIT

ISSUED: MAR 26, 2007

STANDARD NO. PW-4.03